



PV Inverter

SUNNY TRIPOWER

5000TL / 6000TL / 7000TL / 8000TL / 9000TL

User Manual

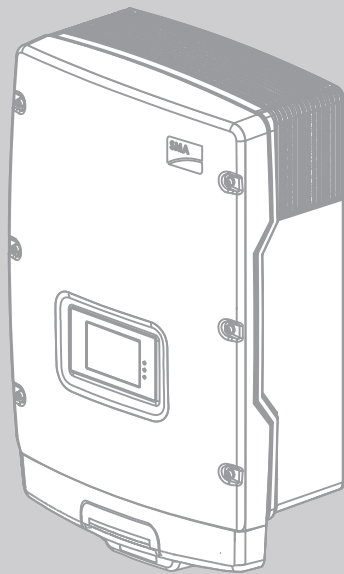

Table of Contents

1	Information on this Document.	5
2	Safety	7
2.1	Intended Use.	7
2.2	Safety Precautions.	8
3	Product Description	9
3.1	Sunny Tripower.	9
3.2	Display	11
3.3	Type Label	14
3.4	Electronic Solar Switch (ESS)	16
3.5	Communication.	16
4	LED Signals.	17
5	Cleaning the Inverter	18
6	Glossary	19
7	Contact	20

1 Information on this Document

Validity





This document is valid for the following device types as of firmware version 2.00:

- STP5000TL-20
- STP6000TL-20
- STP7000TL-20
- STP8000TL-20
- STP9000TL-20

Target Group

This document is intended for end users.

Symbols

Symbol	Explanation
 DANGER	Indicates a hazardous situation which, if not avoided, will result directly in death or serious injury
 WARNING	Indicates a hazardous situation which, if not avoided, could result directly in death or serious injury
 CAUTION	Indicates a hazardous situation which, if not avoided, could result in minor or moderate injury
NOTICE	Indicates a situation which, if not avoided, could result in property damage
	Information that is important for a specific topic or goal, but is not safety-relevant
<input type="checkbox"/>	Indicates an essential requirement for achieving a specific goal
<input checked="" type="checkbox"/>	Desired result
X	A problem that might occur

Nomenclature

Complete designation	Designation in this document
Electronic Solar Switch	ESS
PV plant	Plant
SMA Bluetooth® Wireless Technology	Bluetooth
Sunny Tripower	Inverter, product
SMA Webconnect function	Webconnect function

Abbreviations

Abbreviation	Description	Explanation
AC	Alternating Current	–
DC	Direct Current	–
EC	European Community	–
EMC	Electromagnetic Compatibility	–
LED	Light-Emitting Diode	–
PV	Photovoltaics	–
VDE	Verband der Elektrotechnik Elektronik Informationstechnik e.V.	Association for Electrical, Electronic and Information Technologies

2 Safety

2.1 Intended Use

The Sunny Tripower is a transformerless PV inverter with two MPPT trackers, that converts the direct current of the PV array into grid-compliant three-phase current and feeds this into the electricity grid.

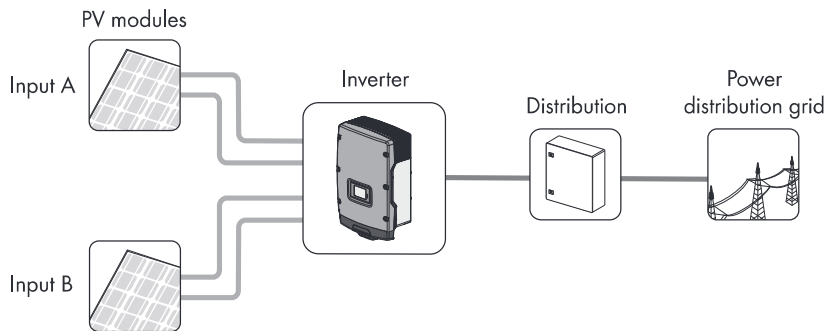

Figure 1: Design of a PV plant with Sunny Tripower

The Sunny Tripower is suitable for indoor and outdoor use.

Alternative uses of the Sunny Tripower not expressly recommended by SMA Solar Technology AG are not permitted.

For safety reasons, it is not permitted to modify the product or install components that are not explicitly recommended or distributed by SMA Solar Technology AG for this product.

The enclosed documentation is an integral part of this product.

- Read and observe the documentation.
- Keep the documentation in a convenient place for future reference.

2.2 Safety Precautions

Electric Shock

High voltages that can cause fatal electric shocks are present in the live components of the inverter.

- Do not open the inverter.
- All work on the inverter (e.g. repairs, modification) must be carried out by skilled persons only.

Burn Hazards

Some parts of the enclosure can become hot during operation.

- During operation, only touch the protective cover and the display.

Yield Loss

Poor heat dissipation can lead to yield loss.

- Do not place any objects on the enclosure.

Inverter Damage

Overvoltages can destroy the inverter.

- If the display message DC overvoltage - Disconnect generator is shown, inform your installer IMMEDIATELY.

3 Product Description

3.1 Sunny Tripower

The Sunny Tripower is a transformerless PV inverter with two MPPT trackers, that converts the direct current of the PV array into grid-compliant three-phase current and feeds this into the electricity grid.

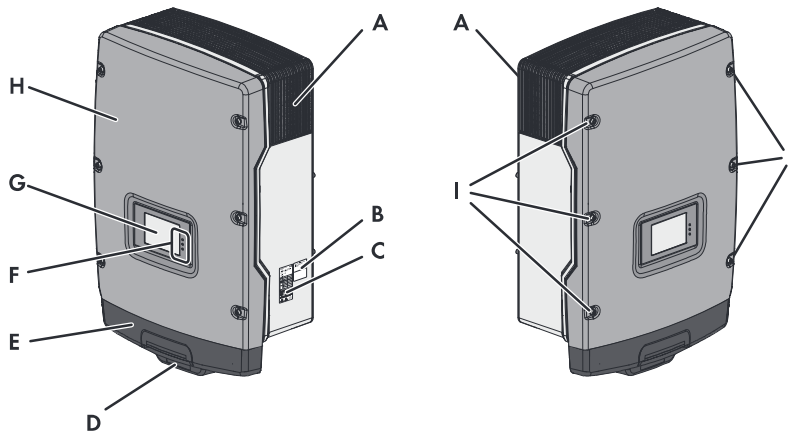





Figure 2: Design of the Sunny Tripower

Position	Designation
A	Ventilation grids
B	Additional sticker on the type label
C	Type Label
D	Electronic Solar Switch
E	Protective cover
F	LEDs
G	Display
H	Enclosure lid
I	Screws and conical spring washers of the enclosure lid

Symbols on the Inverter

Symbol	Designation	Explanation
	Inverter	This symbol defines the function of the green LED. The green LED indicates the operating state of the inverter.
	Observe the documentation.	This symbol defines the function of the red LED. The red LED indicates an error. <ul style="list-style-type: none"> • Contact installer.
	Bluetooth	This symbol defines the function of the blue LED. The blue LED indicates that communication via Bluetooth is activated.
	QR Code [®]	By scanning this QR Code [®] , the solar power professional installing the inverter can register the inverter and take part in the SMA bonus programme.

3.2 Display

The display shows the current operating data of the inverter (e.g. current power, daily energy, total energy) as well as any events and errors. The energy and power are displayed as bars in the diagram.

The display values may deviate from the actual values and must not be used for billing purposes. The values measured by the inverter are required for the operational control and to control the current to be fed into the electricity grid.

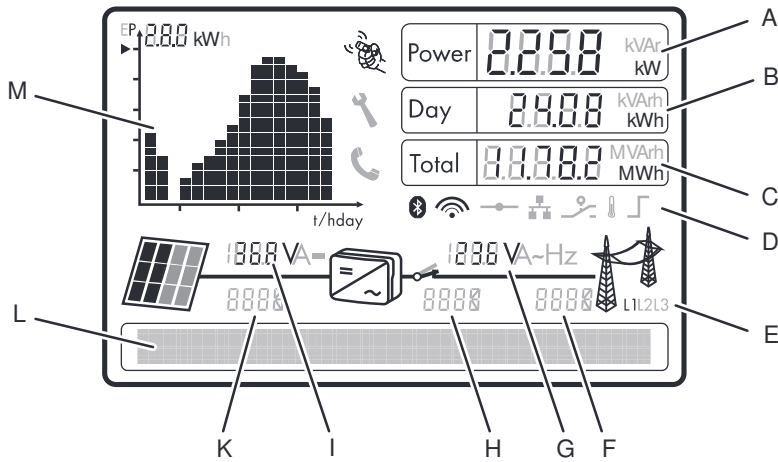















Figure 3: Design of the display (example)

Position	Designation	Explanation
A	Power	Current power
B	Day	Daily energy
C	Total	Total amount of energy fed in until now
D	Active functions	The different symbols indicate which functions are enabled or active for communication, grid management or temperature derating.
E	Line conductor	Line conductor to which the displayed values are assigned
F	Event number relating to the electricity grid	Event number of errors relating to the electricity grid
G	Output voltage/ output current	Displays output voltage and output current of a line conductor in alternation
H	Event number relating to the inverter	Event number of errors relating to the inverter

Position	Designation	Explanation
I	Input voltage/ input current	Displays input voltage and input current of one input in alternation
K	Event number relating to the PV array	Event number of errors relating to the PV array
L	Text line	Displays the event or error message
M	Power and yield curve	Changes in power over the last 16 feed-in hours or the energy yields over the last 16 days <ul style="list-style-type: none"> In order to switch between the displays, tap once on the enclosure lid.

Symbols on the Display

Symbol	Designation	Explanation
	Tapping	You can operate the display by tapping on the enclosure lid: <ul style="list-style-type: none"> Tapping once: to activate the backlight, to scroll to the next text line, to switch between the power graph of the last 16 feed-in hours and the energy yields of the last 16 days. Tapping twice: the display alternates automatically between the firmware version, serial number of the inverter, NetID, IP address, subnet mask, the configured country data set and display language.
	Telephone receiver	Indicates that an error cannot be rectified on site. <ul style="list-style-type: none"> Contact installer.
	Spanner	Indicates an error that can be rectified on site by your installer. <ul style="list-style-type: none"> Contact installer.
	Bluetooth	Indicates that an active Bluetooth connection is established
	Bluetooth connection quality	Indicates the quality of the Bluetooth connection to other Bluetooth devices.
	Speedwire	Indicates that there is a connection to a network

Symbol	Designation	Explanation
	Webconnect function	Indicates that connection to Sunny Portal is possible
	Multi-function relay	Indicates that the multi-function relay is active
	Thermometer	Indicates that the power of the inverter is limited due to excessive temperature
	Power limitation	Indicates that the external active power limitation via the Power Reducer Box is active
	PV array	–
	Inverter	–
	Grid relay	A closed grid relay indicates that the inverter is feeding into the electricity grid. An open grid relay indicates that the inverter is disconnected from the electricity grid.
	Electricity grid	–

3.3 Type Label

The type label uniquely identifies the inverter. The type label is located on the right-hand side of the enclosure. Next to the type label, you can find an additional sticker with information on how to register in Sunny Portal.

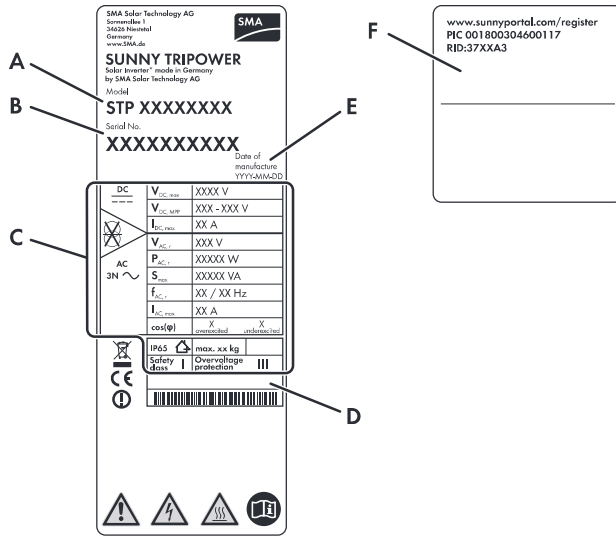

















Figure 4: Design of the type label and the additional sticker

Position	Designation	Explanation
A	Model	Inverter device type
B	Serial No.	Inverter serial number
C	Device-specific characteristics	–
D	Additional information	Field for additional information, e.g. country-specific standards
E	Date of manufacture	Inverter manufacture date (year-month-day)
F	Additional sticker	Internet address, identification key (PIC) and registration key (RID) for registration in Sunny Portal

You require the information on the type label to use the inverter safely and for and for SMA Service Line support. The type label must be permanently attached to the inverter.

Symbols on the Type Label

Symbol	Designation	Explanation
	Danger to life due to high voltages	The product operates at high voltages. All work on the inverter must be carried out by skilled persons only.
	Risk of burns from hot surfaces	The product can become hot during operation. Avoid contact during operation.
	Observe the documentation.	Observe all documentation that is supplied with the product.
	Danger	If a second protective conductor is required, the inverter enclosure must be additionally earthed.
	DC	Direct current
	Without transformer	The product does not have a transformer.
	AC	Three-phase alternating current with neutral conductor
	WEEE marking	Do not dispose of the product together with the household waste but in accordance with the locally applicable regulations for electronic waste.
	CE marking	The product complies with the requirements of the applicable EC guidelines.
	Device class ID	The product is equipped with a wireless component and complies with device class 2.
	Degree of protection	The product is protected against dust intrusion and water jets from any angle.
	Outdoor	The product is suitable for outdoor installation.

Symbol	Designation	Explanation
	RAL quality mark for solar products	The product complies with the requirements of the German Institute for Quality Assurance and Labelling.
	Certified safety	The product is VDE tested and complies with the requirements of the German Equipment and Product Safety Act.
	C-Tick	The product complies with the requirements of the applicable Australian EMC standards.

3.4 Electronic Solar Switch (ESS)

The DC switch-disconnector consists of an ESS and the DC connectors. The ESS must be securely inserted into the underside of the inverter and may only be removed by a skilled person.

A Bluetooth antenna, increasing the radio range, is integrated into the ESS.

3.5 Communication

The inverter is equipped with Bluetooth communication as standard. Additionally, it features Speedwire communication with Webconnect function.

The inverter can communicate with special SMA communication products (e.g. data logger, software) and other inverters via Bluetooth.

If you would like to communicate via Bluetooth, you can protect the inverter with a plant password for the user and a plant password for the installer. All inverters are delivered with a standard plant password for the user (0000) and a standard plant password for the installer (1111). To protect the plant from unauthorised access, you must change the plant passwords using Sunny Explorer (for information on changing the plant password, refer to the Sunny Explorer help).

If you do not want to communicate via Bluetooth, have the Bluetooth communication deactivated by a skilled person. This protects your PV plant from unauthorised access.

You can connect the inverter to your network via Speedwire. If you use the Webconnect function and have registered your plant in Sunny Portal, Sunny Portal can call up the latest data from your inverter (for information on how to register your PV plants in Sunny Portal, refer to the Sunny Portal user manual at www.SMA-Solar.com).

4 LED Signals

The LEDs indicate the operating state of the inverter.

Designation	Status	Explanation
Green LED	glowing	Operation In the case of an event, the event message is shown in the display.
	flashing	The requirements for connecting to the electricity grid have not been met.
Red LED	glowing	Error The display shows the error message and event number. <ul style="list-style-type: none">• Contact installer.
Blue LED	glowing	Bluetooth communication is activated.

5 Cleaning the Inverter

- **NOTICE**

Damage to the display due to the use of cleaning agents

- If the inverter is dirty, clean the enclosure lid, the display and the LEDs using only clean water and a cloth.

6 Glossary

Bluetooth

Bluetooth is a radio technology that allows the inverter and other communication products to communicate with each other. For Bluetooth communication, the Bluetooth devices do not need to be within sight of each other.

Energy

Energy is the power that a system can supply or consume within a certain time unit. Energy is measured in Wh (watt hours). If, for instance, your inverter feeds in for half an hour at 3,000 W and half an hour at 2,000 W, it will have fed a total of 2,500 Wh into the electricity grid.

Power

Power is the product of voltage and electrical current strength. Power is measured in W (watts). The power shown in the display is an instantaneous value. It indicates the power that your inverter is currently feeding into the electricity grid.

7 Contact

If you have technical problems, first contact your installer. The following information is required in order to provide you with the necessary assistance:

- Inverter device type
- Inverter serial number
- Firmware version of the inverter
- Special country-specific settings of the inverter (if applicable)
- The type and number of PV modules connected
- Mounting location and mounting altitude of the inverter
- Three-digit or four-digit event number and display message of the inverter
- Optional equipment, e.g. communication products
- Type of use of the multi-function relay

SMA Solar Technology AG
Sonnenallee 1
34266 Niestetal, Germany
www.SMA.de

SMA Service Line

Inverters: +49 561 9522 1499
Communication: +49 561 9522 2499
Fax: +49 561 9522 4699
E-Mail: ServiceLine@SMA.de

The information contained in this document is the property of SMA Solar Technology AG. Publishing its content, either partially or in full, requires the written permission of SMA Solar Technology AG. Any internal company copying of the document for the purposes of evaluating the product or its correct implementation is allowed and does not require permission.

SMA Factory Warranty

The current warranty conditions come enclosed with your device. These are also available online at www.SMA.de and can be downloaded or are available on paper from the usual sales channels if required.

Trademarks

All trademarks are recognized even if these are not marked separately. Missing designations do not mean that a product or brand is not a registered trademark.

The Bluetooth[®] word mark and logos are registered trademarks owned by Bluetooth SIG, Inc. and any use of such marks by SMA Solar Technology AG is under license.

QRCode[®] is a registered trademark of DENSO WAVE INCORPORATED.

SMA Solar Technology AG

Sonnenallee 1

34266 Niestetal

Germany

Tel. +49 561 9522-0

Fax +49 561 9522-100

www.SMA.de

E-Mail: info@SMA.de

© 2004 to 2012 SMA Solar Technology AG. All rights reserved

